

Development of an Internet of Things - based Fish Feeding Robot Prototype with a Water Level Monitoring System for Pond Use

^[1]Abdul Kadir Muhammad and ^[2]Dermawan

^{[1][2]} Center for Mechatronics and Control System, Mechanical Engineering Department,
State Polytechnic of Ujung Pandang, Indonesia

^[1] kadir.muhammad@poliupg.ac.id, ^[2] dermawan@poliupg.ac.id,

Abstract—

The purpose of this study is to develop an internet of things - based fish feeding robot prototype that equipped with a water level monitoring system for pond use. The robot prototype presented in this paper consists of a feed storeroom tank, a feed distribution mechanism, a feed ejection mechanism, an ejector position turning mechanism, a water level monitoring system, a base and a solar panel system for energy sources. The feed storage tank and the water monitoring system used an ultrasonic sensor, respectively. The three mechanisms used a DC motor actuator, respectively. An internet of things – based control and monitoring system was designed to control the robot and to monitor level of feed in the tank as well as water in the pond. Performances of the robot prototype were tested through laboratory scale experiments. The result of the conducted experiments are presented and discussed.

Index Terms—Aquaculture robot, Fish feeding robot, Internet of Things application, water level monitoring system.

I. INTRODUCTION

One of the fastest-growing food sectors in the world is aquaculture [1] [2]. In aquaculture activities, the frequency of feeding fish is very important because it will affect the amount of feed consumed, feed efficiency and the possibility of environmental contamination. Environmental pollution will affect the health and survival of fish. However, the current feeding activity is still mostly done manually so it is not effective because the distribution of feed is uneven and sometimes not on time. Furthermore, monitoring of water level of pond is another important thing. Sometimes the water level rises after heavy rains which if handled too late can cause the pond to overflow, especially in tropical area.

In the last decade, a number of fish feeding automatic mechanism have been investigated by researchers [3 – 7]. Wei et al [3] and Osueke et al [4] designed automatic fish feeder machine that focused on design and construction. Nasir Uddin et al [5] investigated automatic fish feeder with water temperature monitoring whereas Balagi et al [6] investigate automatic fish feeding with pH and temperature monitoring. Karningsih et al [7] develop automatic fish feeding system for an offshore aquaculture unit.

The purpose of this study is to develop an internet of things - based fish feeding robot prototype that equipped with a water level monitoring system for pond use. Method to achieve the purpose was design and manufactures the robot as well as testing and robot prototype refinement.

The system used in this paper consists of a feed storage tank, a feed distribution mechanism, a feed ejection mechanism, an ejector position turning mechanism, a base and a solar panel system for energy sources. The three mechanisms used a DC motor actuator, respectively. Finally, the performances of the robot prototype were tested in a laboratory scale environment.

II. DEVELOPMENT OF AN INTERNET - BASED FISH FEEDING ROBOT PROTOTYPE WITH A WATER LEVEL MONITORING SYSTEM

A. Mechanisms Design

Figure 1 shows the model of the fish feeding robot prototype. The system of the robot consist of a feed storage tank, a feed distribution mechanism, a feed ejection mechanism, an ejector position turning mechanism, a water level monitoring system, a base and a solar panel system for energy sources, as shown in Fig.2.



Fig. 1. The 3-D model of the Fish Feeding Robot Prototype

Figure 3 shows the three mechanisms. The mechanisms used a DC motor actuator respectively. The feed storage tank made of water drums with diameter of 38[cm] and height of 65 [cm]. On the lid of the tank, an ultrasonic sensor was installed to measure percentage of feed in the tank.

The feed distribution mechanism functions to regulate the flow of feed from the tank to the feed thrower according to the desired portion. The feed distribution mechanism consists of a valve, two cylinders as feed channel with diameter of 9 [cm] and height of 7 [cm], and a DC motor. The motor moved the valve from the point of drop of the feed to the input of the feed ejector with a rotation angle of 360 degrees in a clockwise direction. The motor would stop shortly after turning 180 degrees and then would rotate again. The valve served to move feed from the tank on and off, measured the portion of feed, and then leaded the feed to the ejector to be thrown into the pond. The quantity of feed can be set based on the number of rotations of 180°. The distribution mechanism also played a role in regulating the rhythm of the feed to be ejected so that there was no buildup in the ejection mechanism, and did not burden the ejector motor.

The feed ejection mechanism consists of a planetary gear DC motor and used a propeller connected directly to the motor shaft to eject the feed. At maximum speed the ejector be able to throw up to 9 [m] forward. Furthermore, the ejector position turning mechanism functions to change the direction of the ejector by an angle of 90 degrees. To the right 45 degrees and to the left 45 degrees so that the feed can reach a wider area and make feeding evenly distributed. The ejector position turning mechanism consists of a cylinder with diameter of 9 [cm], a sprocket and a DC servo motor. The sprocket attached to the side while the lower end of the turning mechanism was connected to the ejection mechanism. The turning mechanism and the driving motor were connected using a chain so that they move in the direction of rotation of the driving motor. At the base, a sliding device was added to reduce friction when changing the direction of the ejector. The mechanism was driven by the DC servo motor.

The charging process uses a 20 WP solar panel. A 12 [V] battery with a current of 7.5 [A] was used. The solar panel was connected to the charge controller. If the battery is fully charged then the solar panel charging automatically stops.



Fig.2. Experimental fish feeding robot prototype with a water level monitoring system developed in this research



Fig.3. Feed storage tank and the three mechanisms of the fish feeding robot prototype

B. Water Level Monitoring System

Figure 4 shows the water level monitoring system developed in this research. The monitoring

system consists of a tube that was dipped to water, and an ultrasonic sensor to measure the level of water in pond. Water level of the pond can be monitored through a smart phone by online.

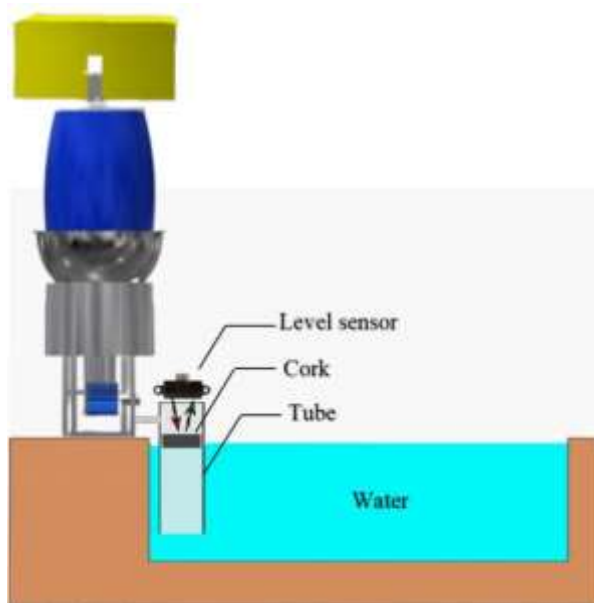

Fig.4.The water level monitoring system

C. Configuration of Control and Information Systems

Figure 5 shows system configuration of the internet of things – based fish feeding robot prototype with water level monitoring system. The robot was controlled by ESP32 Module based on set point that set in computer. Three motor drivers were used to drive three DC motor that rotated for the three mechanisms. A relay was used to switch on and off the driver. A solar panel and a solar charge controller were used as the energy source system. A battery of 12 [V] was used to store power generated by the solar panel system. An adaptor with outputs of 5 [V] and 5 [V] was used to step down the voltage from the battery. The ESP32 module is connected to a smart phone through internet. Level of feed in the storage tank, level of water and level of battery can be monitored through the smart phone by online.

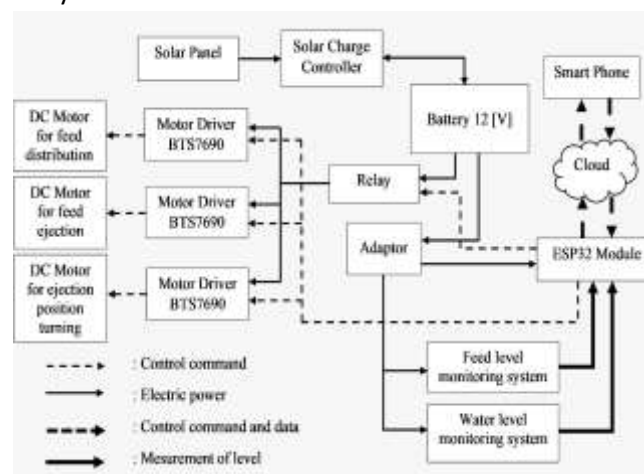

Fig.5.System configuration of the internet of things – based fish feeding robot prototype with a water level monitoring system developed in this research

III. EXPERIMENTS

A. Experimental Method

. The experiment was conducted on a horizontal surface. The experiment goal was to test the performances of the robot in term of mass of ejected feed, feed throw distance and monitoring through information the information system. The first experiment was conducted to test performance of the robot in term of mass of ejected feed. Two containers were installed alternately under the distribution feed mechanism to accommodate the outgoing feed. The feed was then weighed to determine the mass of feed that comes out. This experiment was carried out for 1 [minute] with a sampling time of 10 [seconds]. Each sample taken was then weighed.

The second experiment was conducted to test the performance of the robot in terms of feed throw distance. The Robot prototype ejected the feed while rotating 45 degrees to the right and 45 degrees to the left. This experiment was carried out for 1 [minute] with a sampling time of 10 [seconds]. Feed throw distance was measured every 1 sample.

Level of feed in the storage tank, level of water and level of battery can be monitored through the smart phone by online during the experiments.

B. Experimental Results

Figure 6 shows the performance of the robot prototype in term of mass of ejected feed. It can be seen in Fig.6 that masses of ejected feed are consistence in range of 183 [g] to 185 [g]. Figure 7 shows the performance of the robot prototype in term of feed throw distance. It can be seen in Fig.6 that feed throw distances are consistence in range of 5.5 [m] to 5.8 [m]. The experimental results revealed that the robot can work consistently. A captured window of the smart phone showed the monitoring results can be seen in Fig.8.

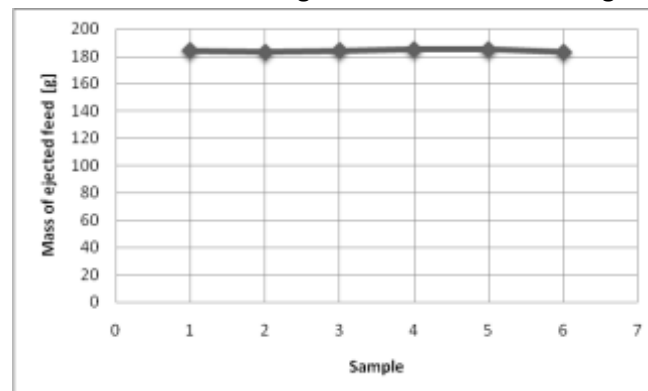

Fig.6. Mass of ejected feed experiment performance of the fish feeding robot prototype

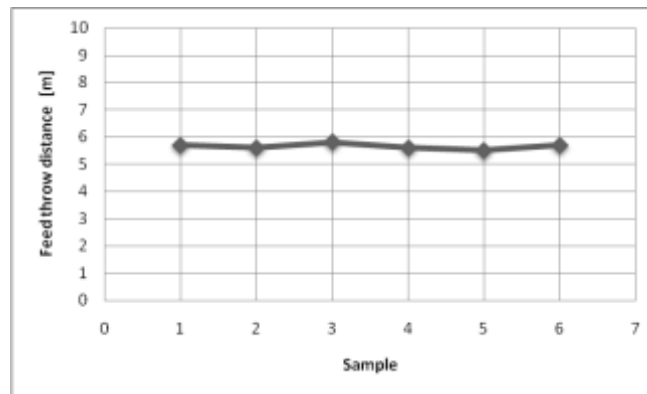

Fig.7. Feed throw distance experiment performance of the fish feeding robot prototype

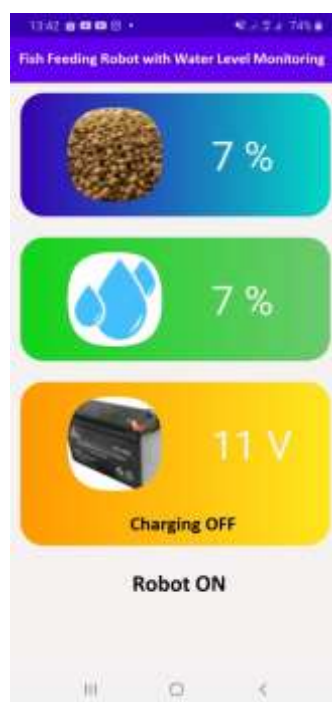

Fig.8. Monitoring of the internet of things – based fish feeding robot prototype with a water level monitoring system captured from the used smart phone

CONCLUSION

In this present study, the internet of things – based fish feeding robot prototype with the water level monitoring system and solar panel system was developed. Three mechanisms namely the feed distribution mechanism, the feed ejection mechanism and the ejector position turning mechanism which are main part of the feeding system were developed effectively. The monitoring systems of feed level in the storage tank, water level and battery level have been developed and equipped to the robot. Performances of the robot prototype were tested through laboratory scale experiments. The experimental results revealed that the robot can work consistently.

ACKNOWLEDGMENT

This work was supported by Ministry of Education, Culture, Research and Technology, Republic of Indonesia, with Grant Number of 099/E4.1/AK.PT/2021.

REFERENCES

- [1] A. O. Ogunlela, A. A Adebayo, "Development and performance evaluation of an automatic fish feeder," *J. Aquac. Res. Dev.*, vol. 7, no. 2, 2016.
- [2] I. C. Liao, "Trends and perspectives in Asian aquaculture," Report of The APO Seminar; 2001.
- [3] H. C. Wei et al, "Improvement of automatic fish feeder machine design," *IOP Conf. Series: Journal of Physics: Conf. Series* **914**, 2017.
- [4] O. C. Osueke et al, "Design and construction of an automatic fish feeder machine," *Int. J. Mech. Eng Tech.*, vol. 10, pp. 1631-1645, 2016.
- [5] Md. Nasir Uddin, et al, "Development of an automatic fish feeder," *Glo. J. Res. Eng*, vol. 16, no. 2, 2016.
- [6] A. S. Balaji et al, "Automatic fish feeding and monitoring system for aquarium using 555 timers," *Int. J. Tech. Res. Sci.*, vol. 5, no. 6., pp. 20-23, 2020.
- [7] P. D. Karningsih et al, "Automated fish feeding system for an offshore aquaculture unit," *IOP Conf. Series: Material Sci. Eng.*, **1072**, 2020.