

Independent Portable Data Copier For Data Transfer

Maheswaran S¹, Sathesh S², Indhumathi N³, Ajith Kumar P⁴, Gomathi R D⁵, Kaveya P⁶

¹ Associate Professor, Department of Electronics and Communication Engineering, Kongu Engineering College, Erode -638060, India, mmaheswaraneie@gmail.com

² Assistant Professor, Department of Electronics and Communication Engineering, Kongu Engineering College, Erode -638060, India, sathesh808@gmail.com

³ Assistant Professor, Department of Electronics and Communication Engineering, Kongu Engineering College, Erode -638060, India, indhunatarajan18@gmail.com

^{4,6} Scholar, Department of Electronics and Communication Engineering, Kongu Engineering College, Erode - 638060, India, ajiikec007@gmail.com

⁵ Assistant Professor, Department English, Kongu Engineering College, Erode, TamilNadu, gomathimaheswaran6@gmail.com

Abstract—

Copying information from one memory storage to another is hindered with many constraints such as the availability of pc. Doing memory operations between memory storage devices in remote areas become virtually impossible if computers weren't available. To overcome this problem, we came up with the idea of a portable device capable of interfacing memory storage devices and perform memory operations like copy, move, delete, etc. Hence the user can copy files from one memory system to other in absence of help of a PC. Our device also has internal storage so that the person can back up their data. To make the device user-friendly, we have included simple applications like Music Player, Calculator and Notepad which we use in our day-to-day life. In addition to such features we have included some high-end features like GSM and Bluetooth. GSM facilitates the person to make phone calls and text at the same time. Bluetooth can help in communicating with other Bluetooth enabled devices and in transferring small sized files. To make the device portable, we have added battery which supports 7 hours of continuous operation.

Keywords— Data Copier, Communication, Portable, SD Card.

I. INTRODUCTION

In this developing digital-world the memory gadgets are truncated in price, bigger in capacity, and tiny in size [7,14]. SD card which loaded in the slot will allow pc to write and read data and files which is safe and secured. This persistent type of memory card has many real-world applications such as video games, cameras, music players, video players, pc, mobile phones and many more. This is tiny sized packed memory card that we can manipulate easily [20]. With the help of decoder software there will be elimination of drive mechanism it is possible to play video, songs, and many more. Technically three types of transfer mode is in existence with SD card. Independent commands and data channels are the one-bit SD mode available first type. It has significant established transferring unit. Second is SD card with Four-bit additional pins and allotted pins. Final mode is SPI mode with direct and coherent subsection of protocol. SDHC, mini SD, microSD are some of the parts of Flash memory card. Other features existing in this SD card will make this user friendly and well favoured for utility. For Data exchange and transfer it is not suited to carry pc or laptop every time where ever you travel in this period of handy portable devices period and also people won't be fond of carrying. A lot of power will

be wasted at the time of data transfer from computer to USB or other devices and the pc should be effectively functional before sending data. The malware and virus effect have made the system users life much complicated than usual [2]. Common system users don't understand the effect of virus and how the system getting infected. In a different way, many traders generate antivirus software with many non-identical features to safeguard or delete these viruses from people's computers [8].

II. LITERATURE REVIEW

In the modern world of computers and technologies multiple ways of storing platform are available electronically and digitally, one among them is use of pen drive, but the problem here is that only with the availability of computer or laptop it is possible for data transfer and no other way for files exchange between USB without computer[1,10]. To store information encrypted an original assured USB drive was designed and to ensure the safety of stored data inside at the time of detection, user identification and verification, by putting in software or hardware-based data protection/loss, obstruction of random data copying, and data cleaning technologies. To avoid the deplorable exposure of data, files and important information to strangers there emerges an emergency demand of necessary plan [9]. However, malicious hackers and data stealers have hacked and extorted the stored information and data due to improper implementation of security functions and due to limitation in environment of current data storing platform [3,19]. Another problem in existing solution is transferring files using internet software. There will be no transaction can be made without using internet meanwhile there will be stable internet connection all the time [12].

A. Existing System

The methodologies that are used for transferring files from one SD card to another SD card.

- Desktops or laptops are used to transfer files from one SD card to SD card.
- Fetching laptop/PC wherever you go is not possible these days for data transfer where the people in this century are fond of being the device to be handheld. Additionally, exchanging information and files with the help of computer demands lot of power to be wasted [11].

B. Disadvantages of Existing Systems

The disadvantages in the existing systems are as follows:

- Difficulty in portability.
- Device availability is low in remote areas
- Separate power source is required.
- Photographers have to buy laptops or desktops to copy photos.
- Copying between multiple SD cards is not possible.

III. PROBLEM STATEMENT

In Order to terminate the utilization of PC or laptop for transferring or exchanging data numerous researches were followed up in embedded system field. Nowadays, the need for transferring files from one SD card to another SD card is rapidly increasing due to the wide spread of mobile phones with SD features. The mobile users have to transfer songs, video clips, and other information. The photographers are also in need to transfer the images from SD cards in camera to a permanent storage device such as

hard-disk. Without the aid of desktops or laptops, such data copying is virtually impossible. These devices are not compact and are not portable for transferring files in remote areas. Hence, we are in need of a portable data copier to transfer files. Our device is compact with TFT colour display which gives a better visualization. Since the data transfer takes place through SPI port, it offers an enhanced speed. In addition, we have added high end features such GSM module for making voice calls and texting the messages. To make our device friendlier to the users we have added audio player applications and other small applications such as note pad and calculator. Parallel processing is an added advantage where speed will not be a constraint.

IV. PROPOSED SOLUTION

Our project helps in copying raw data directly from one SD card to another. The problem in copying data from one SD card to another is that, it is not possible without the help of accessories like computers or desktops. The portable data copier we made is compact and allows copying of data between SD cards[15].

We can interface multiple SD cards with our device, which enables memory operations like copy, cut, and delete to be performed on these cards. Our device has a 3.4" TFT Touch screen 320x240 pixels in 16-bit colour with a touch screen, which is used to view the files in SD card using the file explorer. We have now interfaced three SD cards. The microcontroller used in our project is PIC 32MX460L512H. The microcontroller has 5 stages pipeline which enables superior performance. It has 2 UART ports, 2 SPI ports and an USB port.

We have interfaced the three SD cards through SPI ports. The SPI is a simultaneous serial interface which is helpful for contacting with outer peripherals and other microcontroller devices. The SPI has user-configurable 8bit, 16 bit and 32bit width, separate SPI FIFO buffers for transmit and receive. The SPI port has 4 pins SI, SO, SCLK, CS. The chip select signal is used to select between the three SD cards. We read the files in the SD card using the file format FAT32. The FAT32 Controller acts a mediator between USB Controller Module and the File Manager sub module. It is responsible for extracting the File System only then the File Manager sub module could easily access the File System [5]. DMA controller helps in copying the files from one card to another quickly. The device also has an image viewer.

The program for various operations such as copy, cut, and paste are coded using embedded c language and compiled using the software Mikroelektronika PRO for PIC32. To enhance the features of our project, we have interfaced GSM module and Bluetooth. GSM module helps the user to make calls and send text messages. We have created keypad to dial numbers to make calls and notepad to create text messages. The GSM module has been programmed by using "AT" commands. The GSM module has been interfaced to the microcontroller through UART port. Bluetooth is interfaced through UART communication. Bluetooth helps is searching other Bluetooth devices and connect with them. Pairing of Bluetooth devices is possible only after exchange of pass keys. It helps in transfer of small files. An audio player is also created which plays mp3 files.

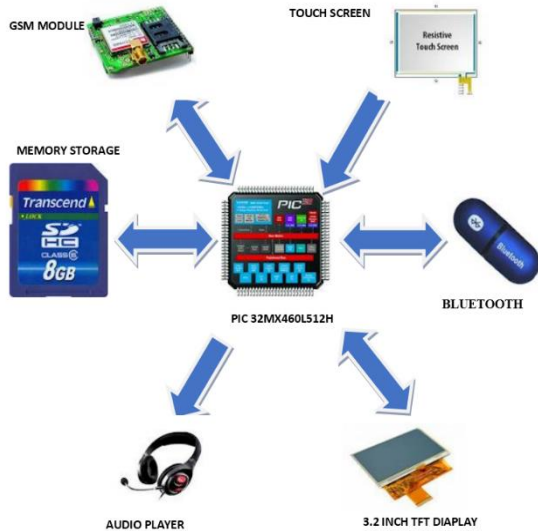

Fig. 1 block diagram of portable data copier

V. SYSTEM OPERATION

A. Power supply unit

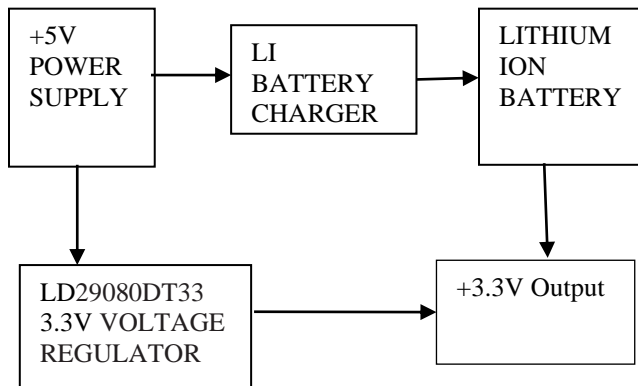

Fig. 2 Block diagram of power supply unit

Since low dc voltage is required for all electronic circuits to work and voltage supply needs a power supply. This unit consists of a 5V input power supply and a 3.3V battery.

A Lithium-ion battery of specification 3.3V, 800mAh is used to provide the required power supply to the unit. Since we use a battery for the power supply, our main objective of making the device portable is achieved. An internal battery charger (MCP73832) is used to charge the Lithium Ion battery from the 5V supply. A regulator IC (LD29080DT33) is used to provide constant DC supply of 3.3V to the unit.

B. Components

Regulator

The output voltage from the battery is regulated and given to the units. The constant output

voltage is maintained by voltage regulator, irrespective of the change in load variations, temperature changes and supply variations. Hence LD29080DT33 is used which is a +3.3V regulator. The LD29080 is a low-dropout, high accuracy and high current Voltage Regulators series. Very low ground current and 400mV dropout voltages will be provided by these regulators. These regulators also finds applications in lower current, low dropout critical systems, and designed for high current loads. Their important attributes are ground current values and tiny dropout voltage.

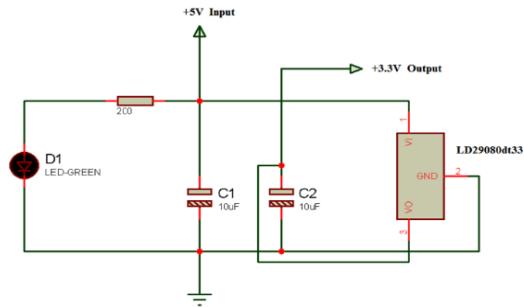

Fig. 3 Power Supply Regulation Unit

Lithium Ion Battery

Lithium-ion batteries are favored because of its maximum number of advantages:

- Rechargeable batteries are heavier than but lithium batteries are lighter in weight.
- In 1 kilogram of battery it can store up-to 150 watt-hours of electricity.
- They hold their charge. 5% of the charge in lithium battery will be lost every month.
- There is no existence of memory effect, which indicates that there is no need of complete discharge before recharge.
- Hundreds of charge and discharge cycles can be handled by Lithium-ion batteries.

Operation of Lithium-Ion Batteries

This body of metal battery holds a lengthy spiral comprising triple thin sheets comprised together:

- '+' electrode
- '-' electrode
- A separator

The sheets inside the body are immersed in an electrolyte which is an organic solvent and the common solvent used is ether. Very tiny sized sheet of micro perforated plastic is the separator. It implies that it's function is to separate positive and negative electrodes meanwhile it allows for the ions to pass through. Lithium cobalt oxide or LiCoO_2 is used in production of positive electrode. Carbon is used in negative electrode. At the time of charging lithium ions move through the electrolyte from +ve to -ve electrode and will get attached to carbon. The lithium ion will get back to Lithium cobalt oxide from carbon during the time of discharge. This cell produces 3.7 volts at the time of movement of ions of lithium which takes place at a constant high voltage. Comparing to the cell that you buy from supermarket it is much better AA alkaline cell, as it is much better than the 1.5 volts.

COLOUR TFT DISPLAY WITH RESISTIVE TOUCH:

TFT display is intense (4 white colored LED), high (3.4" oblique) and radiant (16-bit 262,000 multiple

shades) [13,16].240x320 pixels with unique pixel control; this has more clarity than a white and black 128x64 display. Resistive touchscreen displays are controlled of different layers that are divided by small spaces [4]. When TFT-LCDs viewed on head on it shows a sharp image but they also represent poor viewing angles often [6]. Two flexible sheets that are with a insulation material which is called the Resistive touch screens, which are chopped by an air gap or microdots and also called as touch sensitive computer displays. Metallic layers are of two types in existence. Matrix is the first type of metallic layer which is striped electrodes will face each other like glass or plastic. Analogue is the second type of metallic layer which has transpicuous electrodes facing each other without pattern. Analogue also offers lowered production costs. When surface is made to the have contact with the touch screen, the two sheets will be compressed together. Registration of the accurate location of the touch there will be two sheets like vertical and horizontal lines.

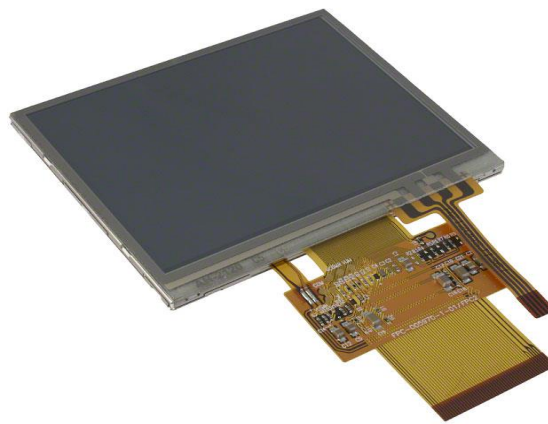

Fig. 4 TFT display with touch screen

5.2.4 GSM module

A GSM module is used for vocal communication, working on 900MHz frequency, (for vocal communication it should be connected to a tiny speaker and microphone) and for SMS. On four sides it looks like an L shaped big package (dimension: (0.94 x 0.94 X 0.12) inches) externally. AMR926EJ-S is the processor manages the module controls data communication (TCP/IP stack), phone communication internally. This processor also manages the SIM card (3 or 1.8 V) that gets attached to modules outer wall. Moreover, an Real Time Clock, an I²C, an analog interface, an A/D converter, an Serial Peripheral interface bus, and a Pulse Width Modulation module. The module is provided with constant energy (in between 3.4 and 4.5 V) and inhales an extreme of 0.8 A during transfer.



Fig. 5 SIM900 Module

AT commands:

AT commands also known as Hayes AT commands. Both mobile and ordinary devices get instructions from AT commands. The commands will be sent to the modem that got connected to phone, which may be a PC modem and GSM modem. Calling variety, reading, setting the SMSC number, removing an SMS, trying to find a GPRS access point, reading the battery status, scanning and removing phonebook data, signal strength reading are the operations performed with the help of AT commands as an example.

SD CARD

SD card is a small memory storage that is efficient to build memory handy among different devices, such as eBooks, music players, camcorders, pc, PDAs, digital cameras, car navigation systems, cellular phones. SD card qualities an excessive data exchange rate and tiny battery usage, both supreme deliberation for handheld devices. It functions with spark memory to give persistent memory, which represents to restore data power supply is not required.

An SD card weighs about 2 grams and it will be on the size of a post stamp. Both SD and MMC cards provide protection content with its encryption capabilities to check protected assigning of copyright gadgets, such as video, music player, and electronic Books. SD cards are associated with memory capacities as long as 4 gigabytes.

BLUETOOTH MODULE

Bluetooth is an established unlatched transatlantic technology for transferring files over small distances (small-wavelength radio conveyance in the ISM band from 2400MHz–2480 MHz) from constant and android devices, with high level security of establishing personal area networks (PANs). It can able to contact number of devices, get the better of simultaneous difficulty.

IMPLEMENTATION OF BLUETOOTH MODULE

Bluetooth functions with radio technology mentioned as frequency-bounding extended spectrum, which separates the data being dispatch and receive spieces of 79 bands (each 1 MHz; in between of 2402MHz to 2480 MHz) establishing in between 2,400MHz –2,483.5 MHz (authorizing for guard bands). This range is under the internationally unapproved Medical, industrial and science 2.4 GHz small-extent radio frequency band.



Fig.6 Bluetooth module

VI. RESULTS AND DISCUSSION

The device has a TFT display for viewing the file management. Portable data copier is handy and hence it is easily portable. The battery backup in the laptops is up-to 2 or 3 hours. It has an external battery backup which lasts power for nearly 7 hours. Transferring files from one SD card to multiple SD cards is possible in the proposed method. Reading, writing, copying, deleting and editing of files are also possible. GSM module has been interfaced to the proposed model to make it user friendly. The user can make voice calls and send message through the device. Many additional features have been included to the model such as audio player application that plays mp3 songs parallel processing can be done during these operations. Other small applications such as calculator, notepad has been included. Calculator is used to perform various operations on numbers and display the result on the TFT display. Notepad is use to get alphabet variables and display them through which editing operations can be performed on the text file. Bluetooth module is interfaced to the device. Operations such as Device searching and pairing can also be done. Through Bluetooth module small files can be transferred up to a distance of 10m. It will be useful to the photographers to transfer files in a easy way without the need systems in remote areas. It has internal memory so back up files can also be done.

A. Main Menu Screen

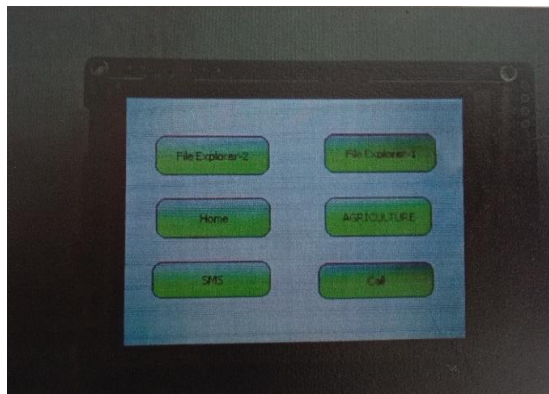

Fig. 7 Image of Main Screen

Figure.7 represents the main screen. While switching on this portable device this is what the screen appears on the TFT display after flash screen. This screen will have options like File Explorer-2, File Explorer-1, Home, Agriculture, SMS, Call. On clicking the required option we will have the screen or the particular function starts ongoing.

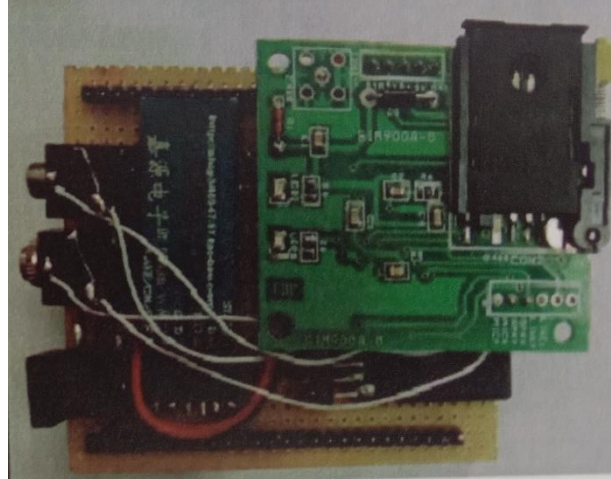

Fig. 8 Rear View of The Hardware

B. Hardware Developed



Fig. 8 Front view of the hardware

Figure.8 shows the front view of the developed portable device which is the flash screen that appears at the time of switching ON. Figure.9 represents the rear view of the portable device with the modules named GSM module, Bluetooth module, SD card, TFT display pin configuration and thePIC 32MX460L512H controller.

C. Agricultural Application

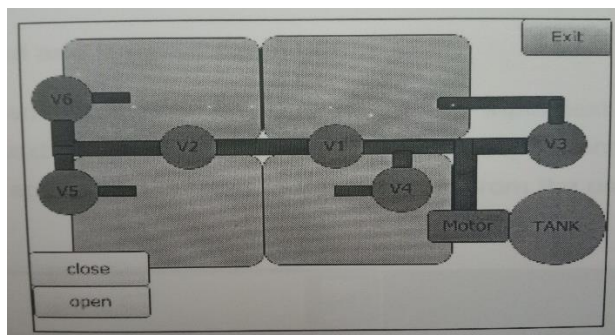

Fig. 10 Image of agricultural application

Figure.10 represents the image of the agricultural application present in the device with the agricultural components as valves, pipes, and motor. An Agricultural application has been built to increase the effectiveness of the user interface with the agricultural systems. The fields, pipes, valves, motors, and crop description are all given to the device and the system updates the status of it through GSM module and delivers to the users. The user can thus control the agricultural appliances through this module.

D.GSM Applications

The GSM applications such as messaging and calling are used in this device. The GSM module is interfaced with the device through UART communication.

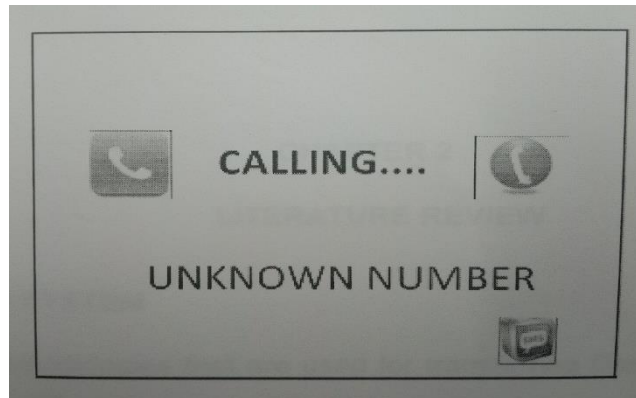

Fig. 11 Image of GSM application

Figure.11 shows the image of the calling screen of the device. This screen is used to make or receive calls and to view text messages.

E. NOTEPAD AND KEYPAD APPLICATIONS

Notepad application is used to get the input text from the user and to process the text files. This application gets text files for sending text messages etc. The keypad application is used to get numbers from the user for calling and other input functions.



Fig. 12 KeypadApplication

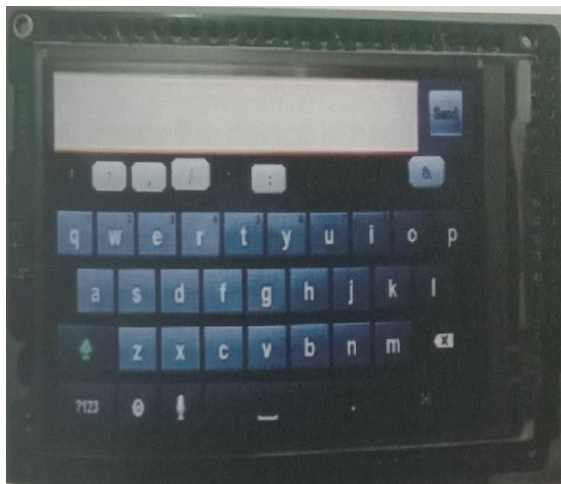

Fig. 13 Notepad Application

Figure.12 and 13 shows the image of the notepad and keypad that contains all numbers and buttons to get the user data input.

F. AUDIO PLAYER APPLICATION



Fig. 14 Image of audio player

Figure.14 shows the image of audio player application used in the device. The audio files from the SD card are explored and are sorted out for the audio files. These files are then read and sent to audio codec IC for decoding the audio files. The communication between the codec and the controller is done using SPI communication. The decoded audio output is obtained from the devices.

VII. CONCLUSION

The transfer of files from one SD card to another SD card is done through the Portable data copier. The device is more compact in size and portable hence it can be used in remote areas. The battery backup of this device lasts for 5 hours. It has many user-friendly applications such as notepad, calculator that makes it more attractive. High featured applications such as GSM module and Bluetooth module has been interfaced to the device through which voice and data communication is possible. Transfer of small files can be achieved through Bluetooth module. Transfer of files from one SD card to multiple SD card can also be done. Touch screen has been used to select among the options which overcomes the mechanical worn out. Audio player has been incorporated in this device. Hence the device is handy with many user applications.

References

- [1] AamirChaugule, Abid Ansari, Junaid Khan, Maroof Khan and Ashafque Shaikh, "A Proposal for Portable Data Transfer", International Journal of Advanced Research in Computer and Communication Engineering, Vol. 6, Issue 9,2017.
- [2] V.S.Gawali,A.M.Agarkar, "Pen Drive to Pen Drive and Mobile Data Transfer Using ARM", IOSR Journal of Electronics and Communication Engineering (IOSR-JECE), PP: 43-47.
- [3] Kyungroul Lee,Insu Oh, Yeunsu Lee, Hyeji Lee, KangbinYim and JungtaekSeo, "A Study on a Secure USB Mechanism That Prevents theExposure of Authentication Information for Smart HumanCare Services", Journal of Sensors, Volume 2018.
- [4] Sukhada M. Deshmukh, Prof. R.C.Mahajan, "Data Transfer between Two USB Devices without using PC", International Journal of Engineering Technology Science and Research, Volume 2 Issue 7, 2015.
- [5] Prof. Rakesh R. Yadav, Prof. MonaliPatil, Prof. Vijay Gupta, "USB to USB Data Transfer without Pc", International Journal for Research in Applied Science & Engineering Technology (IJRASET), Volume 5 Issue IX, 2017.
- [6] Sonal N. Kawale, Rahul Dhuture, "USB to USB and Mobile Data Transfer WithoutConnecting to PC Using Arm Processor", International Journal of Engineering Research and Applications (IJERA), PP 22-25, 2014.
- [7] Jewan Bang, ByeongyeongYoo, Sangjin Lee, "Secure USB bypassing tool", Elsevier, S114-S120, 2010.
- [8] Manasi Mali, Harshal More, SnehashreeMhatre, Nilesh Mali, Prof. Amit Chougule, "Implementation of Anti-Drive", International Research Journal of Engineering and Technology (IRJET), Volume: 06 Issue 04, 2019.
- [9] Kyungroul Lee, KangbinYim and Eugene H. Spafford, "Reverse-safe authentication protocol for secure USBmemories", Security and Communication Networks, 5:834–845, 2012.
- [10] Priyanka Bapat, Neha Lodh, RatnaPolas, Swati Pulkurte Prof. RupaliDalvi, "USB TO USB Data Transfer Without Connecting To PC", International Journal of Engineering Research & Technology (IJERT), Vol. 2 Issue 2, 2013.

- [11] Rupali C. Bachalkar, Shrutika D. Durge, Purvaja V. Pote, Sapana V. Ajmire, Prof. Reetesh V. Golhar, "Data Transfer between Two Pendrives without PC", International Journal of Advanced Research in Computer Science and Software Engineering, Volume 5, Issue 1, 2015.
- [12] VineetaSoni, Mrs. SarveshTanwar, "Data Transfer without using Internet or Bluetooth", International Journal of Scientific & Engineering Research, Volume 5, Issue 1, 2014.
- [13] Lalit, Anurag Sharma, Arun Agarwal, Vijay Sharma, Amit Srivastava, and Varun Maheshwari, "Data Transfer with the Help of USB Host Controller without PC", International Conference on Communication, Control and Intelligent Systems (CCIS), PP 433-436, 2015.
- [14] DarshanaRarath, Mayank Sharma, Akshay Mane, Pooja Dabral and Roshani Ade, "Computer Independent Data Transfer Device", The International Journal of Engineering and science, – Vol. 5, No. 2, 2017.
- [15] VanaparthYupendhar, AnandBabu, "Device - to - Device communication (Pen drive) without PC", International Journal of Advance Research, Ideas and Innovations in Technology, Volume3, Issue6, 2017.
- [16] Sukhada M. Deshmukh, Prof. R.C.Mahajan, "Handheld Device for Data Transfer between Two USB Sticks", International Conference on Information Processing (ICIP), PP 647-651, 2015.
- [17] S Maheswaran, B Vivek, S Sathesh, and K PonVignesh, "An Autonomous Wheeled Robot System to Remove the Dust Congestion in Drip Irrigation", 9th International Conference on Advanced Science and Engineering Research, 2020.
- [18] B Vivek, S Maheswaran, P Keerthana, S Sathesh, S Bringeraj, R Akshaya Sri, and S AsmaSulthana, "Low Cost Raspberry Pi Oscilloscope", 2018 International Conference on Intelligent Computing and Communication for Smart World, PP 386-390, 2018.
- [19] Murugan G, Sriram V.P, Ambika M, KollaBhanu Prakash, SudhakarSengan, Priya V, and Pankaj Dadheech, "Implementation of New Secure File Transfer Protocol Using Triple-DES and MD5", International Journal of Advanced Science and Technology, Vol. 29 No. 06, 2020.
- [20] UvehPahlavan, and Allen H. Levesque, "Wireless Data Communications", IEEE, Vol. 82, No. 9, 1994.