

## Micro-Strip Patch Antenna Performance Analysis With Tlm Derived Circuit Model

**Dr.Monika Bhatnagar, Dr. K Hussain, Dr Devashree Marotkar, Poonkodi R, A. Ushasree,  
I.Ravi Kumar,**

1 Associate Professor, Department of Electronics and Communication Engineering, Galgotias College of Engineering and Technology, Greater Noida-201306, U.P,India,[monikabhatnagar06@gmail.com](mailto:monikabhatnagar06@gmail.com)

2 Associate Professor & Head, Department of EE, Sharad Institute of Technology College of Engineering, Yadrav (Ichalkaranji), Kolhapur, Maharashtra-416121, [hussain16679@gmail.com](mailto:hussain16679@gmail.com)

3 Assistant professor and Head Department of Electronics and Telecommunication Engineering, G H Raison Institute of Engineering and Technology , Hingana- Wadi link road, Nagpur, Maharashtra-440028, India, [devashree.marotkar@gmail.com](mailto:devashree.marotkar@gmail.com)

4 Assistant Professor, Department of Computer Science and Engineering, Sri Eshwar College of Engineering , Coimbatore-641202, [poonkodi.r@sece.ac.in](mailto:poonkodi.r@sece.ac.in)

5 Assistant Professor, Department of Department of Electronics & Communication Engineering, Gokaraju Rangaraju Institute of Engineering and Technology, Bachupally, Nizampet Rd, Kukatpally, Hyderabad, 500090, Telangana, India, [ushasreemishra@gmail.com](mailto:ushasreemishra@gmail.com)

6 Assistant Professor, Department of Electronics & Communication Engineering, Bharat Institute of Engineering and Technology, Hyderabad, 501 510, Telangana, India, [iravikumar@biet.ac.in](mailto:iravikumar@biet.ac.in)

---

### Abstract

This project aims to investigate and construct an accurate Transmission Line Method/Circuit Model by modeling the rect micro-strip patch utilizing 2 simulation studies: the Methods of Moments & TLM. Every span has 2 rectangular patch component units, that are very carefully modeled. The array, which is made up of many units of this fundamental construction, was made to resonate at a freq of 2GHz for 3G/UMTS. Microwave Studio TM software is used to simulate both feeding networks. Two pairs of simulations (utilizing Circuit Model/Transmission Line Method & Methods of Moments) will be used to analyze & predict every method. Both can be compared to see how much they differ in terms of bandwidth, resonant frequency & S<sub>u</sub>. The Methods of Moments-simulated structure is then built & evaluated to see how different the hardware and 2 simulation groups are fabricated on a 4.7 relative permittivity (FR-4) board. At the intended frequency of 2GHz, antennas constructed & simulated for every feeding model obtained the best returning loss, with S<sub>u</sub> values less than -10dB. At the same moment, both arrays generated a reasonable amount of bandwidth for their class, which is roughly 2percentage. In terms of S<sub>u</sub> and resonant frequency, the CM reported in this study differs from its Methods of Moment's equivalent by less than 9%, however, it performs poorly when utilized to forecast bandwidth efficiency.

*Keywords:* Transmission Line Method; Technique of Moments; bandwidth performance

### 1. Introduction

MICRO-STRIP patch antennas have several recognized benefits under other antenna constructions, with their small profile & therefore nature of conformal, low capacity, small manufacturing price, robustness & compatibility [1]. Several numerical techniques, such as MOM & TLM, could be produced by a group of authors to help with algorithmic work while building microstrip patch antennas. Previous research [2] described the creation of a single component of an accurate CM to

ease system performance & evaluation. The endeavor to implement this single CM in the form of arrays would be reported in this paper.

The Methods of Moments could be utilized to estimate & analyze the performance of a single-component antenna. Methods of Moments replicate the structure, volume, and location of passive distributed circuits while also taking into account their proximity as well as area & platform radiation. The overall antenna construction is broken down into smaller units called 'meshes' in this simulation method. The electromagnetic waves of the mesh, as well as their interactions, are computed [3]. The outcomes are then added together to produce a forecast for tower effectiveness. For every single component patches tower, requires painstaking repetition & solution for function of Green's utilizing Sommerfeld category integrals, as well as the price in terms for simulation period & pc assets is substantial.

Furthermore, when single pieces are repeated & coupled in the form of an array, either through the corporate / series feeding approach, this technique becomes even more period and resource-intensive, making it an unwise strategy for bigger structures. As a result, employing an analogous CM, which requires the creation of a CM [5], is another useful approach to studying and predicting antenna performance.

CMs, on the other hand, have a drawback in that they have very limited control over form fluctuations. A plus part, it could be simulated much easily, & sweeps of parameters might be accepted efficiently when optimizing circuits utilizing this method. Even though the CM approach uses far fewer resources than Methods of Moments, precision is compromised in the name of simplicity [9]. To put it another way, the true issue in adopting the Circuit Model approach is giving & modeling a precise model that is close adequate to Methods of Moments [10] outcomes in terms of performance.

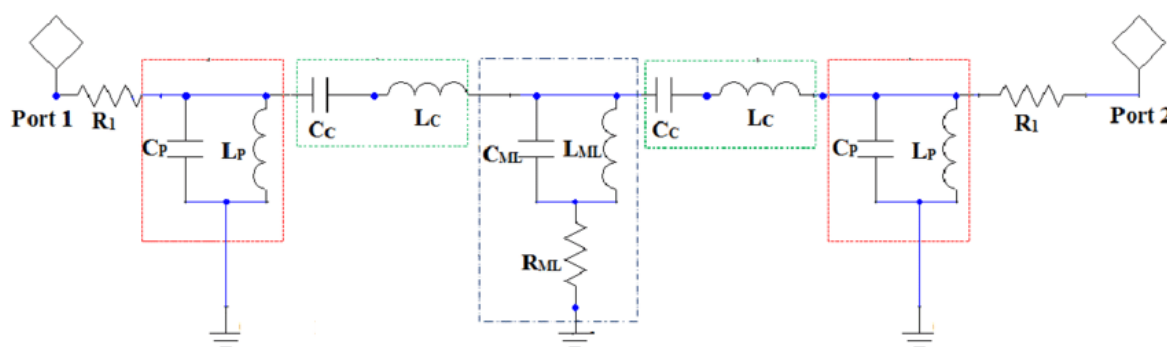

Figure 1: Circuit model for microstrip antennas

## 2. Related works

This makes use of the previously published precisely specified single component rectangle Circuit Models. A 2 component rectangular-shaped micro-strip patch array is created utilizing two widely used array connectivity networks, notably series feed & corporate feed.

A single patch component Methods of Moments sizes, as well as CM [11], are also the basic construction blocks including both arrangements. Already when replication, as well as connectivity, can begin, that is necessary to make sure that both Methods of Moments well as CM for this specific

piece are appropriately modeled. Articles and journals have been used to estimate the CM counterpart of a distribution line-fed rectangular microstrip patch antenna. In contrast to Methods of Moments findings, the overall CM of a partial ground plane area was shown to exhibit a minor fluctuation. Figure 1 shows the corresponding CM for the particular aspect intended to reverberate at the WLAN 802.11b as well as Ultra-wideband wavelength of 2.4 GHz. The satellite's manufacturing platform was FR-4, which has a refractive index of 4.7, a relative dielectric vector of 0.019, as well as a platform length of 1.6 mm. Electromagnetic Studio program was used to do combined CM as well as Methods of Moments models.

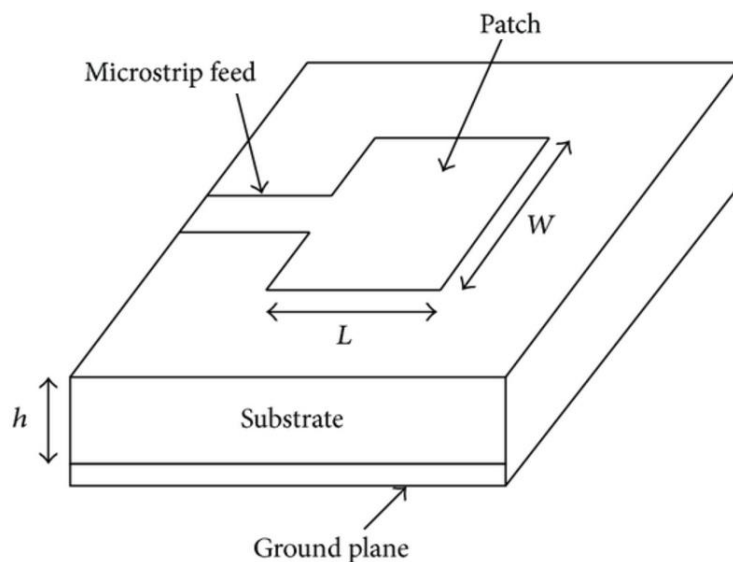

Figure 2: A three-dimensional image of a rectangular microstrip array

The CM would then be optimized to rebound at 2 GHz as a particular aspect before ever being copied as well as spiraled on a commercial circuit configuration as well as a parallel graze system, accordingly, to construct 2 kinds of 2 different rectangle ensembles, which are independently modeled. Like a reference, an analogous Method of Moments model of this arrangement was generated with both graze systems. The transmitter element's equipment was constructed as well as tested as a signature confirmation approach, depending on the Methods of Moments-simulated arrangement measurements [12]. This would be done to see how much variety there would be in two types of simulations. The major material in the manufacture of panels' equipment would be comparable to that seen in the manufacture of single-layer transmitters. In addition, microstrip CAD software was utilized to verify the predicted values. It gives an estimated price for the resonating variables, but still, it takes some fiddling with the device's variables to get the best numerical model at the target frequency [13]. The supply, as well as plug circuit model, was based partly on analysis as well as layout academic journals [14]. Single feature pack core piece was copied as well as linked in such a company network and perhaps a sequence connection, both are widespread as well as successful panel communication strategies. TX LINE, a calculation tool in Electromagnetic Studio, was used to measure the distribution of the serving system utilizing the greatest similarity. As shown by Figure 2, each component was composed of primary transmitter measurements ( $L \times W$ ), a set of bordering areas which each end of the patchwork. That after the edges of the piece, further set for parallel-connected RC networks was inserted along either side of the patchwork as a complement to represent areas at the sudden discontinuity's margins. Computation methods have been used to

corresponding values of the passive components (inductances & resistivity), which would then be supplemented by human adjustment as well as auMOMsatic adjustment for the optimal Q11, bandwidth, as well as frequency range as shown in Figure 3.

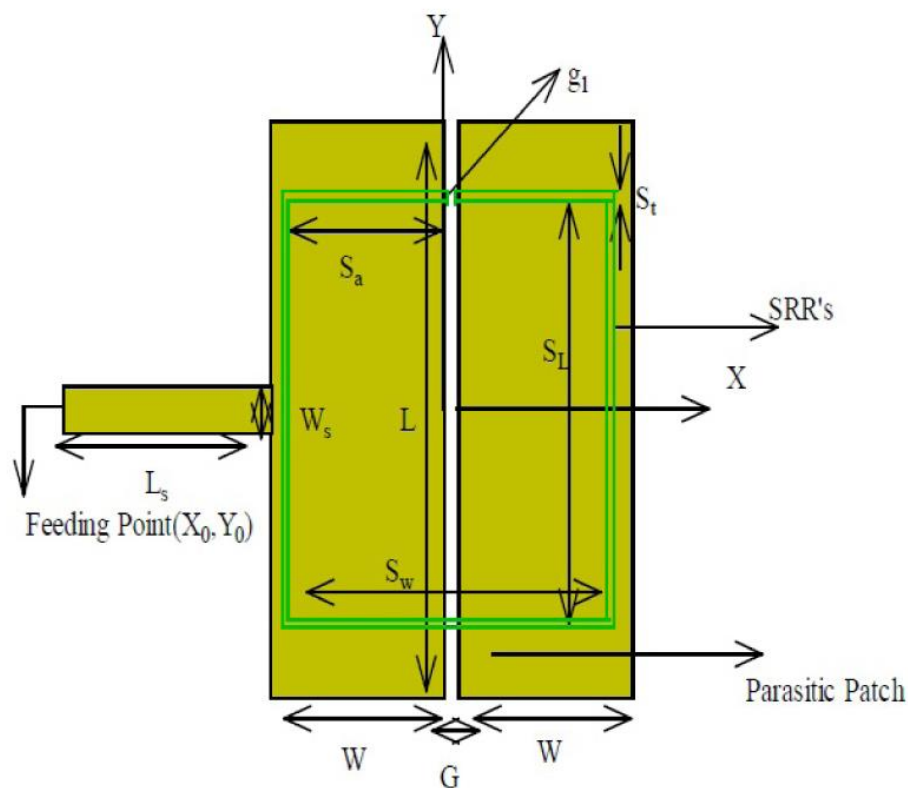

Figure 3: Microstrip patch array dimensions in detail

### 3. Discussion of the Findings

Charts I as well as II, and also Figures 4 and 5 demonstrate the findings including both measured and simulated. The frequency for MOMS modeling for the intended commercial supply network was 47 MHz, whereas the network design was 39 MHz. The quantity of frequency generated was fair since this kind of machine generates limited overhead for an electrically small distribution. The 30 percent frequency discrepancy between the planned network model and the actual transmitter reproduced in the Methods of Moments scenario demonstrates a weak resemblance of the planned equivalent circuit against the actual transmitter. It's was due to the CM's failure to replicate EM field-to-environment interactions, that are properly represented as well as compensated for in a Methods of Moments model as well as computation. In transmitter research, it was a very well disadvantage of the CM approach. From the other side, the CM & actual numbers are nearer, yielding roughly 20%. When contrasted in terms of speed, though, it's not as good as such Methods of Moments solution, which only varies by roughly 14% from the results obtained. Methods of Moments provided a high frequency of 50 MHz again for the proposed parallel supply network, whereas CM was marginally lower. Both modeling methodologies exhibited the very same proportion of inaccuracy, which was 25 percent off the observed data, according to specific device measurements. The frequency variance generated by the Circuit Model relative to Methods of Moments is likewise exceptionally large in this configuration, at over 40%. This supports the previously stated model parameters the Circuit Model's major weakness. The observed throughput for the serial feed arrangement, on the

other hand, was 2.01% higher than the recorded throughput for the corporation feeding arrangement, which would have been roughly 1% less.

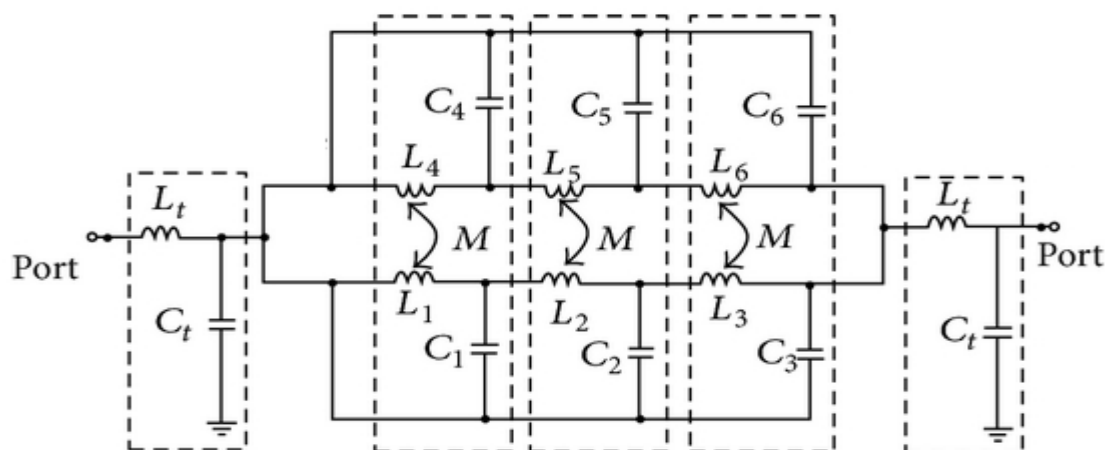

Figure 4 presents the full comparable Circuit Model of the planned business rectangular microstrip arrangement Q11 with all applications.

Because the Q11 would be less than 10 dB, the calculated and observed results were characteristic of a well-functioning station. Thinking at this with the perspective of a business graze transmitter, the Circuit Model method produces great Q11 with such a value of 25.75 dB, next by the Methods of Momentsmethod. The variation in Q11 among Methods of Moments well as Circuit Model methods also was linked. Only approximately 8% of the variance was visible. Subsequent inspection of the tested equipment revealed discrepancies ranging from 19 percent to 27 percent. Methods of Moments-measurement assessment of variance assessment produces a 19.94% similar outcome, but CM differs more and more from the proportion of the total, with such a variance of upwards to 27% shown in Figures 6 and 7.

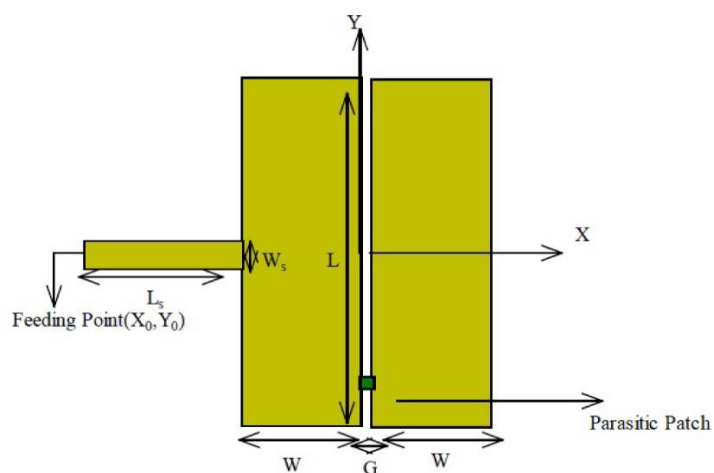

Figure 5: Precise dimensions of the microstrip patch array supplied in series

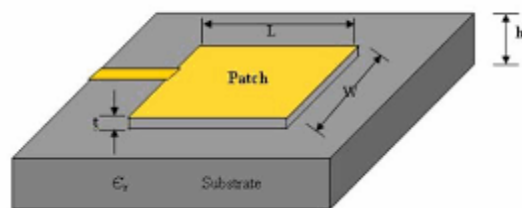

Figure 6: Microstrip patch array in Feed series

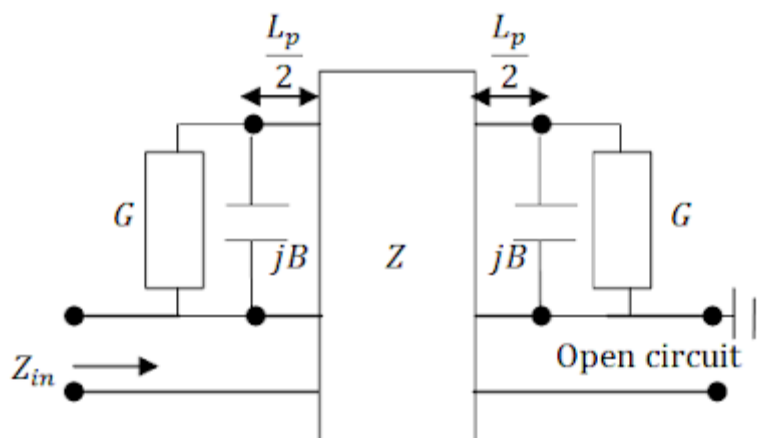

Figure 7: The Circuit model of parallel supply of microstrip

The Methods of Momentsclass graze arrangement architecture, on the other hand, offered a good Q11 rating of 31.25 dB, accompanied mostly by CM's Q11 of 31.04 dB. Data demonstrates that perhaps the suggested CM's forecast of Q11 efficiency was correct, with something like a discrepancy compared with fewer than 0.7 percent. Furthermore, on examining the actual values, the Q11 generated was somewhat inadequate, while remaining within a suitable satellite's range of operation. In contrast to both models, which were in excellent accordance, it still only generated a score of 13.41 dB. As a result, measuring even against kinds of models resulted in inaccuracies of upwards to 60% shown in Figures 8 and 9.

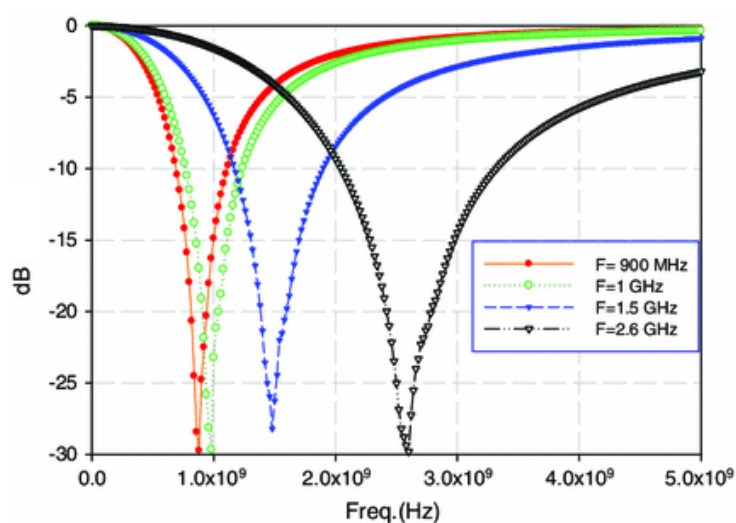

Figure 8: Comparison of simulation and measurement results

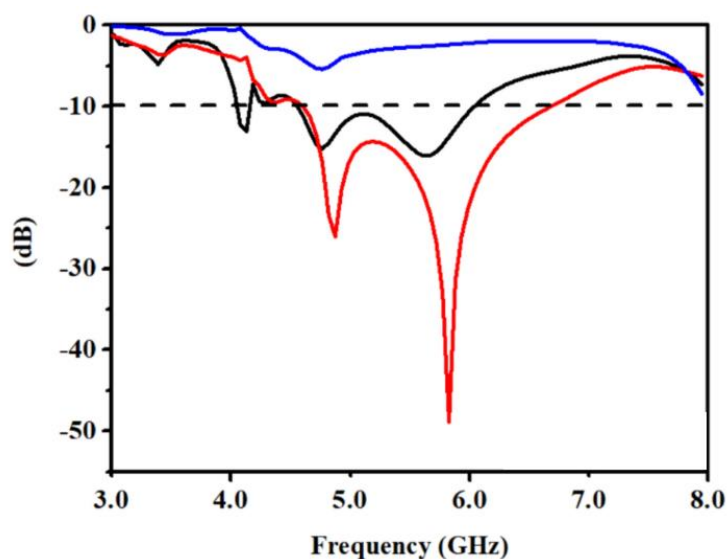

Figure 9: Comparison of simulation with rectangular microstrip array

Its Methods of Moments calculation resulted in a better reflection coefficient at the targeted 2 GHz frequency (Table I and II). Whenever it reverberated at 2.05 GHz, though, the analogous Circuit Model for business graze arrangement shows the minor resonance change. In reality, the Circuit Model-simulated grid provided an outcome that was only 1.91 percent off from the overall data. This would be even nearer than a gap in Methods of Moments results obtained, and that is 4.31 percent. The Circuit Model-Methods of Moments correlation, and on the other hand, shows that perhaps the Circuit Model provided was great at capturing the Methods of Moments model. However, the Circuit Model to parallel graze arrangement created a change in best resonating at 1.97 GHz, whereas the intended Methods of Moments design exhibited zero modification of frequency response, which was consistent only with built equipment. Each of them seems to have a 1.99 GHz optimum frequency. As an outcome, the % variations between Circuit Model- Methods of Moments well as Circuit Model- Calculated were all just under 1%.

The change of frequency response could be due to the graze characteristic impedance being represented as a separate circuit rather than a mixture of inductive and capacitive graze characteristic impedance between both the patched as well as the earth as stated previously [15].

Table 1: Simulated results comparison

Network Feed	Meas	BW in MHz	S in DB	F in GHz	BW in Range	BW in Percent
Corp	SIM (CM)	35	-23	3.06	2-3	2.18
	SIM (MoM)	48	-26	3.03	3-4	3.12
	Meas	40	-19	3.09	4-5	2.92
Series	SIM (CM)	32	-32	2.95	1-2	2.62

	SIM (MoM)	52	-33	2.06	2-3	3.12
	Meas	42	-12	2.07	2-3	3

Table 2: Simulation results of micro strips

Network Feed	Meas	BW in MHz	S in DB	F in GHz
Corp	MoM (CM)	32	9	3
	MoM (MoM)	22	27	2
	Meas	16	21	5
Series	MoM (CM)	41	1	2
	MoM (MoM)	26	57	2
	Meas	27	58	1

#### 4. Conclusion

The comparison modeling technique involving Method of Moments research as well as its counterpart Circuit Model was provided. The greatest return failures were obtained at the intended bandwidth range of 2 GHz by designing 2 kinds of arrays utilizing separate grazing systems. In respect of harmonic resonance and Q11, the suggested Circuit Model as well as the transmitter modeled with Method of Moments are extremely comparable. Its Circuit Model also has decreased modeling effort and expense despite maintaining a great Method of Moments compatibility. In research consideration, this concept can be applied to analyze larger units, such as for ensembles with some more components as well as log-periodic transmitters.

#### References

- [1] Zhi XX, Zhang Y, Zhang XM, Wang HL, Wu L, An YC, Wei XY, Liu JG. Preparation and properties of semi-alicyclic colorless polyimide films and light-colored sheets with low dielectric features for potential applications in optoelectronic integrated circuits. *Express Polymer Letters*. 2021 Nov 1;15(11):1051-62.
- [2] Chhandak M, Deng M, Nodjiadjim V, Riet M, Mismar C, Guendouz D, Caillaud C, Bertin H, Vaissiere N, Luisier M, Wen X. Towards Monolithic Indium Phosphide (InP)-Based Electronic Photonic Technologies for beyond 5G Communication Systems. *MDPI Applied Sciences-Special Issue on State-of-the-art Terahertz Science and Technology*. 2021 Mar 8.



[3] Song Z, Sistani M, Wind L, Pohl D, Rellinghaus B, Weber WM, Lugstein A. Plasmon-Assisted Polarization-Sensitive Photodetection with Tunable Polarity for Integrated Silicon Photonic Communication Systems. *Nanotechnology*. 2021 Sep 20.

[4] Dr.P.Sivakumar, "Analytical framework to build predictive and optimization function from manufacturing industry sensor data using cross-sectional sharing", *Big Data*,2021 (SCI)

[5] Dr.P.Sivakumar, "Improved Resource management and utilization based on a fog-cloud computing system with IoT incorporated with Classifier systems", *Microprocessors and Microsystems*, Jan 2021 (SCI).

**[6]** Ranjeeth, S., Latchoumi, T. P., & Paul, P. V. (2020). Role of gender on academic performance based on different parameters: Data from secondary school education. *Data in brief*, 29, 105257.

[7] Muttlak SG. *Advanced InP/InGaAs Electronic/Optoelectronic Integrated Circuits for High Speed MMIC Applications*. The University of Manchester (United Kingdom); 2020.

[8] Li J, Zhang L, Qin QH. A regularized method of moments for three-dimensional time-harmonic electromagnetic scattering. *Applied Mathematics Letters*. 2021 Feb 1;112:106746.

[9] Ding H, Tian Y, Wen C, Wang C, Sun C. Polydispersed droplet spectrum and exergy analysis in wet steam flows using method of moments. *Applied Thermal Engineering*. 2021 Jan 5;182:116148.

[10] Mukherjee C, Natrella M, Seddon J, Graham C, Mounaix P, Renaud CC, Maneux C. Efficient compact modelling of UTC-photodiode towards terahertz communication system design. *Solid-State Electronics*. 2020 Aug 1;170:107836.

[11] Fu Y, Kang Y, Liu R. Novel bearing fault diagnosis algorithm based on the method of moments for stochastic resonant systems. *IEEE Transactions on Instrumentation and Measurement*. 2020 Aug 19;70:1-0.

[12] Anwar A, Siddique M, Dogan E, Sharif A. The moderating role of renewable and non-renewable energy in environment-income nexus for ASEAN countries: Evidence from Method of Moments Quantile Regression. *Renewable Energy*. 2021 Feb 1;164:956-67.

[13] Mukherjee C, Deng M, Nodjiadjim V, Riet M, Mismar C, Guendouz D, Caillaud C, Bertin H, Vaissiere N, Luisier M, Wen X. Towards Monolithic Indium Phosphide (InP)-Based Electronic Photonic Technologies for beyond 5G Communication Systems. *Applied Sciences*. 2021 Jan;11(5):2393.

[14] Wang H, Chen Y, Zhang J, Zhang G, Huang YC, Gong X. First Demonstration of Waveguide-Coupled Ge<sub>0.92</sub>Sn<sub>0.08</sub>/Ge Multiple-Quantum-Well Photodetector on the SOI Platform for 2- $\mu$ m Wavelength Optoelectronic Integrated Circuit. In *2021 Symposium on VLSI Circuits 2021 Jun 13* (pp. 1-2). IEEE.

[15] Gibson WC. *The method of moments in electromagnetics*. Chapman and Hall/CRC; 2021 Sep 6.