

Solar-Powered Pesticide Sprayer Controlled Remotely

Dr. Ram Bajaj^{1*}

^{1*}RNB Global University-Bikaner

***Corresponding Author:** Dr. Ram Bajaj

^{1*}RNB Global University-Bikaner

Abstract:

With India's population rapidly increasing, there is a pressing need to boost food production while keeping costs affordable. Traditional farming methods prevail in India, despite significant advancements in industry and the service sector compared to agriculture. Mechanization efforts have led to the development of various agricultural equipment, including pesticide sprayers. Traditionally, these sprayers are operated manually by farm workers using backpack-type or electric pump sprayers, which can be labor-intensive and inefficient. To address these challenges and improve the efficiency of agriculture, a new solar-powered pesticide sprayer has been developed. This equipment harnesses renewable energy from the sun, making it eco-friendly and cost-effective. The automatic sprayer is a four-wheeled vehicle designed to spray pesticides across farms with minimal human intervention. It is powered by an onboard solar-powered battery, reducing operational costs. Control of the vehicle is achieved through an integrated microcontroller unit programmed to respond to Bluetooth wireless devices. This project offers a viable alternative to traditional pesticide spraying methods, enhancing agricultural efficiency and reducing labor requirements.

Index Terms – Microcontroller, Solar panel, Bluetooth device.

I. INTRODUCTION

Agriculture is a profession of many tedious processes and practices, one of which is spraying of insecticides in the fields. Sprayers are mechanical devices that are specifically designed to spray liquids quickly and easily. They come in a number of different varieties. In this project we will take a look at solar operated mechanical sprayers. A sprayer of this type is a great way to use solar energy. Solar based automatic pesticide sprayers are the ultimate cost-effective solution at the locations where spraying is difficult. This automatic solar based pesticide sprayers system uses solar energy sources. Solar energy is first used to charge a storage battery. The solar energy stored in the battery is utilized to operate motor which functions as pump. In this project we are trying to make a prototype model for farmers and cultivators for whom spraying of insecticides is harmful and hazardous.

By using this robotics sprayer, we have to reduce manpower. This sprayer is remote control based so hazardous chemical is not affected on human. This sprayer increases the speed of work. It is a multipurpose sprayer. This project work described here is quite useful in the agriculture fields. Agriculture is a profession of many tedious processes and practices, one of which is spraying of insecticides in the agricultural fields. Sprayers are mechanical devices that are specifically designed to spray liquids quickly and easily. They come in a number of different varieties. In this project we will take a look at solar operated mechanical sprayers. A sprayer of this type is a great way to use solar energy. Solar based automatic pesticide sprayers are the ultimate cost-effective solution at the locations where spraying is difficult. This automatic solar based pesticide system uses solar energy as a source. Solar energy is first used to charge a storage battery. The solar energy stored in the battery is utilized to operate motor which functions as a pump. In this project we are trying to make a

prototype model for farmers and cultivators for whom spraying of insecticides is harmful and hazardous “Bluetooth based pesticide sprayer” is used in the agriculture field. Sprayers are mechanical devices that are specifically designed to spray the liquids quickly and easily. They come in a number of varieties. In this project we will take a closer look at solar operated mechanical sprayers. A sprayer of this type is a great way to use solar energy

II. LITERATURE REVIEW

[1] Binod Poudel et al,

Agriculture has a predominant role in our day-to-day life. Spraying of pesticides is an important task in agriculture in order to protect the crops from the danger of pests. Agriculture has been the backbone of the Indian and Nepal economy and culture for a very long time and will continue to do so in the future

[2] Dr. Rajendra M. Rewatkar et al,

The primary objective of this paper is to tackle with this kind of problem in which an automated pesticide sprayer is involved to spray the pesticide to the localized area of the affected crops. The manual method for dealing such a problem is very time consuming and hence the semi automatic pesticide sprayer is introduced

[3] M. Ahalya et al,

This paper presents a semi automatic pesticide sprayer system which operates using a solar power. The vehicle is powered using an onboard solar powered battery which brings down the running cost. The solar energy which is stored in the battery is utilized to operate motor which functions as a pump.

[4] Mr. Ch. Vemaiah et al,

A Solar Powered Automatic Pesticide Spreading robot project is mainly proposed for reduce the manpower and usage of electricity. Solar plate is used to provide the source to the battery charging. It is an automated system for the purpose of grass cutting. The source is driven from the solar energy by using solar plate. The system control is done by the Arduino UNO R3. Automation is achieved by using sensors and Arduino UNO R3. Wheels and cutting operations are done using DC motors.

DC battery is utilized for powering and standby mode operation of the system. The whole supply is provided through the battery and to charge the battery charger circuit is used to provide the charging for the battery. Also the second application is that the spreading of pesticide here we used the water pump with spreading nozzle.

[5] Malatesh D et al,

The existing products for pesticide sprayers are either hand operated (manpowered) or fuel operated (fossil power) which requires high human effort and needs regular maintenance like refilling of fuel which are quite expensive. Traditional agriculture sprayers are in the form of backpacks which on continuous usage creates a back pain or becomes stressful for the users and can only carry a maximum of 10 litres. Our product which is basically a trolley based that eliminates these problems and restriction. It can be easily movable with very less human effort and can carry sufficient amount of pesticide.

[6] Dhiraj N. Kumbhare et al,

We know that people doing farming from ancient time for food and other purpose. For better growth of crop they spray pesticides on them. There are many types of pesticides spraying techniques available now that we can find as we move from east to west and also from north to south. It is difficult to mention all those techniques here. But we tried to mention main techniques used and best known to us. People in India use backpack type sprayer which is carried on back of the person with 15 lit maximum capacities and one nozzle in one hand while other hand is used to pump the machine to create pressure. Another machine which is developed

[7] Abhishek Jivrag et al,

Describes invention and operation of multiple granulated pesticides duster with the use of solar energy. The concoction is accomplished by the use of solar panel, impeller type centrifugal blower, gear reductions mechanism, dispensers, DC motors and batteries. In addition, the duster has been equipped with a facility to operate on an electric supply, which serves beneficial in the absence of sunlight. The device essentially works for disbursing solid granulated form of pesticide. The operator controls the rate and discharge of different pesticides by means of push buttons and toggle switches. The technical specifications of the device are worked and examined in a way to minimize the weight of the device and deplete the feeder unit dispenser in a span of three hours.

[8] J.V.Bhanutej et al,

In India, agriculture has a predominant role in our day-to-day life. The crops that come as yields decides the total production, adds to the economy of the country. The yield decreases due to the presence of pests, Insects In farms. To kill the pests, insects pesticides and fertilizers are sprayed either manually or by sprayers. Earlier the pesticides and the fertilizers were sprinkled manually, but they will result in harmful effects on farmers. In order to overcome this problem, different spraying techniques have been developed. These sprayers consist of different mechanisms and the cost of the equipment is generally high.

We developed a mechanism in which we tried to minimize the equipment cost by removing the pump to spray.

III. METHODOLOGY

Explanation of Flow Chart

- The first step involved in the selection of the project. After weighing in various factors like Feasibility, cost, usefulness and challenges involved we selected this project. This was done after Extensive discussions with our guide.
- After the selection of our project we went on to select the various general elements required for the Project. This involved sourcing a welder and getting a quote on the steel pipes used.
- We next designed the chassis of the sprayer unit, we based this on a guided vehicle structure and Made the necessary modifications.
- The electrical components were selected to best suit the project requirements. The circuit diagram Was used as a basis for selection of components.
- The next step involved two steps carried out almost simultaneously – the fabrication of the model According to the design and putting together the electrical circuits, calibrating the sensors and the Microcontrollers
- After the fabrication of the model and the completion of the electrical circuits, we integrate the mechanical and electronic parts into one unit for further testing.
- We test the integrated unit on accuracy and robustness

If any changes or additions are required, we implement them and re-test until satisfactory results are obtained. Manual operated sprayers are dangerous to human life and fuel consuming. With the help of the above proposed system we can overcome the above said problems. The solar plates convert solar energy and electrical energy is stored in the battery. Using Bluetooth application instruction are sent to the receiver side, with the help of the system we can overcome the problem faced by farmers previously and its greater advantage.

The main components used to fabricate the model are:

- DC Motor
- Battery
- Solar Panel
- Microcontroller
- Nozzle
- DC Pressure Pump
- Wheels
- Pesticide tank

IV. Components used

DC Motor

An electric motor is a machine which converts electrical energy to mechanical energy. Its action is based on the principle that when a current carrying conductor is placed in a magnetic field, it experiences a magnetic force whose direction is given by Fleming's left hand rule. When a motor is in operation, it develops torque. This torque can produce mechanical rotation. DC Motors are also like generators classified into shunt wound or series wound or compound wound motors. The result is to flux density into the region directly above the conductor and reduce the flux density in the region directly below the conductor. It is found that a force acts on the conductor, trying to push the conductor downwards as shown by the arrow. If the current in the conductor is reversed, the strengthening of the flux lines, lines occurs below the conductor, and the conductor will be pushed upwards.



Figure 1. DC Motor Specifications:

Capacity	17 watts
Speed	60 rpm
Type of motor	Shunt motor
Operating volt	12 volt
Power	1 amp

Battery

In isolated systems away from the grid. Batteries are used for storage of excess solar energy converted into electrical energy. The only expectations are isolated sunshine load such as irrigation pumps or drinking water supplies for storage. In fact for small units with output less than one kilowatt. Batteries seem to be the only technically and economically available storage means. Since both the photo-voltaic system and batteries are high in capital costs. It is necessary that the overall system be optimized with respect to available energy and local demand pattern.



Figure 2. battery

Specifications:

Type	Lead acid battery
Capacity	12 volts
Current	7.5AHC

Solar panel

A solar panel, or photo-voltaic (PV) module, is an assembly of photo-voltaic cells mounted in a framework for installation. Solar panels use sunlight as a source of energy and generate direct current electricity. A collection of PV modules is called a PV panel, and a system of panels is an array. Arrays of a photovoltaic system supply solar electricity to electrical equipment.



Figure 3. solar panel Specifications:

Capacity	12 volts
Power	5 watts
Size	12*24 inches
Total power produced	10 watts

Microcontroller

Our system is vehicle type system; hence we need to control the system using a microcontroller. We use ATMEGA LM 328 microcontroller to control our system. This microcontroller having four ports. We use port number Three for the Bluetooth connection. The transmitter of the microcontroller is connected to the receiver Of Bluetooth is connected to transmitter of microcontroller. Following figure shows the pin diagram of microcontroller ATMEGA LM 328.



Figure 4. microcontroller Specifications:

Microcontroller used in this project	ATMEGA LM 328
--------------------------------------	---------------

Nozzle

The proper selection of a nozzle type and size is essential for proper pesticide application. This publication covers nozzle description, recommended uses, selection of the proper nozzle type, and the ounce calibration method. A listing of nozzle manufacturers also is included. The proper selection of a nozzle type and size is essential for proper pesticide application. The nozzle is a major factor in determining the amount of spray applied to an area, the uniformity of application, the coverage obtained on the target surface, and the amount of potential drift. Nozzles break the liquid into droplets, form the spray pattern, and propel the droplets in the proper direction. Nozzles determine the amount of spray volume at a given operating pressure, travel speed, and spacing. Drift can be minimized by selecting nozzles that produce the largest droplet size while providing

adequate coverage at the intended application rate and pressure. Minimizing drift is especially important for herbicides.



Figure 5. flat fan nozzle

Specification:

Nozzle used	Flat fan nozzle
Flow rate of nozzle	2.5-4 GPM

DC Pressure Pump

Diaphragm pump combines the advantages of self-priming pump and chemical pump. Installed in a dry, well-ventilated location; pumps can not work in water. Using a variety of imported corrosion-resistant materials, self-priming, thermal protection, smooth operation, long-time continuous idling, long-time continuous load operation. Totally sealed, high stable pressure. Bracket can absorb vibration from the pump when working. When the water pressure is too high, pump will protect themselves and normal work, water pipes will not burst, it is safe and durable. Pressure protection: pressure switch power protection. The maximum flow of 5 L /min The work: intermittent service (continuous working at different working pressures at different times) The use of media: water or solvent PH value 5–8, oil. Service life: more than 500-1000 hours of continuous work



Figure 6. DC Pressure Pump

Specifications:

Weight	90g
Dimensions	165*50*40mm
Input voltage	12 volts
Flow rate	5lit/min
Material	Plastic & metal

Wheels

In its primitive form, a wheel is a circular block of a hard and durable material at whose center has been bored a hole through which is placed an axle bearing about which the wheel rotates when torque is applied to the wheel about its axis. The wheel and axle assembly can be considered one of the six simple machines. A wheeled vehicle requires much less work to move than simply dragging the same weight. The low resistance to motion is explained by the fact that the frictional work done is no longer at the surface that the vehicle is traversing, but in the bearings. In the simplest and oldest case the bearing is just a round hole through which

the axle passes (a "plain bearing"). Even with a plain bearing, the frictional work is greatly reduced because:

- The normal force at the sliding interface is same as with simple dragging.
- The sliding distance is reduced for a given distance of travel.
- The coefficient of friction at the interface is usually lower.



Figure 7. Wheels

Specifications:

Diameter	15 inches
Thickness	3 inches

Pesticide Tank

A pesticide tank are storage are containers that hold liquids compressed gases o mediums used for the short or long term storage of fluids or gases. The term can be used for reservoirs. Storage tanks are available in many shapes: vertical and horizontal cylindrical open top and closed top flat bottom, cone bottom, slope bottom and dish bottom. Large tanks tend to be vertical cylinders, or to have rounded corners transition from vertical side wall to bottom profile, to easier withstand hydraulic hydrostatically induced pressure of contained liquid. Most container tanks for handling liquids during transportation are designed to handle varying degrees of pressure.



Figure 8. Pesticide Tank Specifications:

Material	Plastic
Capacity	10 litres

V. WORKING PRINCIPLE:

The microcontroller is the main component of the complete system. It consist of two parts the transmitter and the receiver. The transmitter part is the Bluetooth device. The battery, solar panel, and the Bluetooth make up for the input of the system. The reciver consists of the microcontroller, motors, sprinkler motors. The sun rays are collected by the solar panel which converts solar energy into electrical energy and it is stored in the battery. We can use it the direct electrical energy for spraying where as battery can be used as backup for night times usage. Bluetooth is used to send the instructions to the microcontroller unit.

The commands are as follows:

- Forward movement
- Backward movement
- Turn right
- Turn left
- Movement of sprayer upwards
- Movements of sprayer downwards
- Sprinkler start
- Sprinkler stop

SYSTEM AND ASSUMPTIONS

A. Receiver

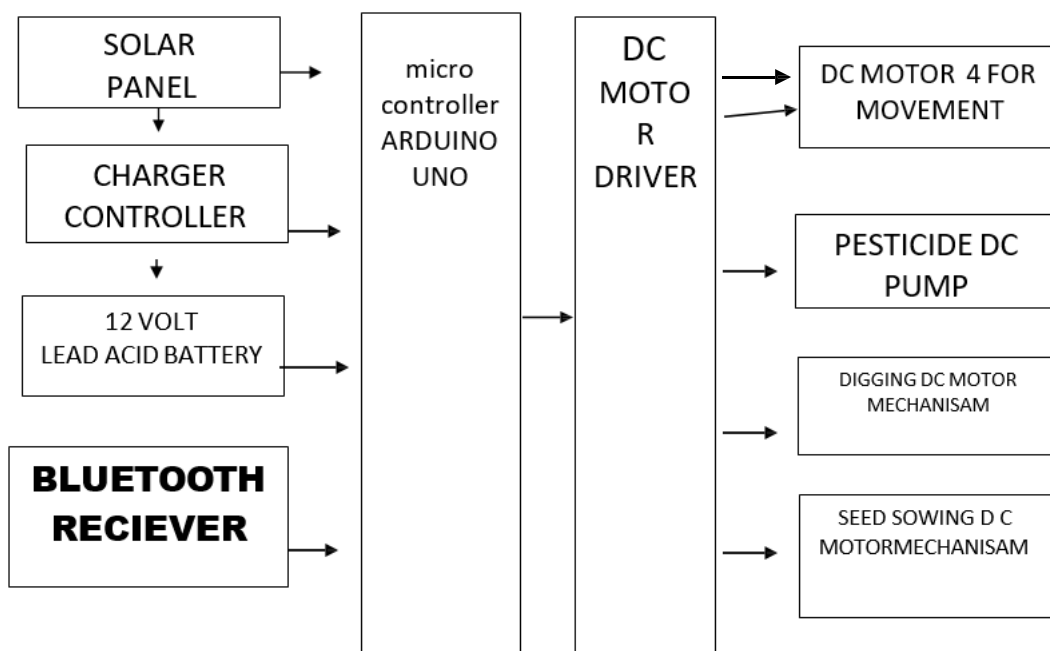

Figure.9. Layout of the Receiver

B. TRANSMITTER



VI. OBJECTIVES

- Human effort can be reduced by bringing automation in the systems by using wireless network system.
- To adopt the solar power into the work for reducing the energy consumptions
- The sprayer and motors are interfered to an Arduino that controls the working of the vehicle.

- To operate pesticide sprayer with zero pollution.

VII. FEATURES

- fast operation and efficient
- Uses renewable energy
- Saves time

VIII. DESIGN

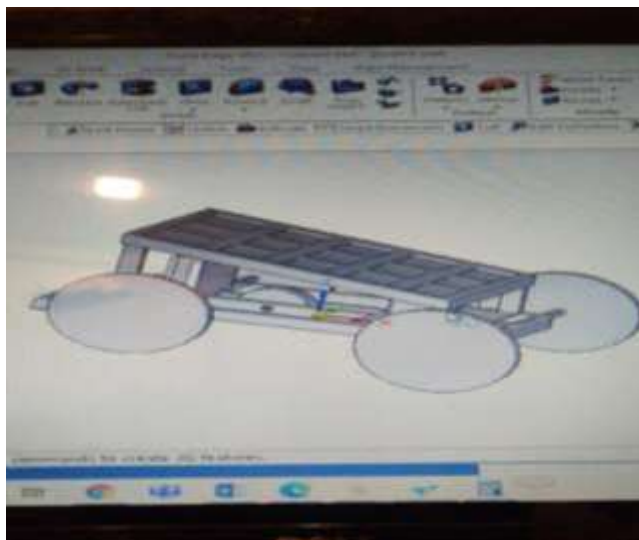

Figure 10. 3D Model Design



Figure 11. Top view of the model



Figure 12. Front view of the model

IX. Results

This agriculturally based vehicle proves to be an effective and efficient machine which can be easily Navigated and controlled. The vehicle can move through different types of terrains and soil. Command for controlling the vehicle movement and spraying of pesticide is done by using an app Called Arduino Bluetooth controller which is available in the play store. Hence control of the vehicle is user friendly, and it is not very complicated;

hence farmers can easily control the vehicle. Pesticide Spraying is a tedious job in agriculture as it requires various protection equipment's to protect the Farmers. This vehicle mainly emphasis on pesticide spraying by framers from a remote location Without directly encountering it. This feature will encourage more people to take up Agriculture as the complexity of the task is reduced and the manned task is converted to an Unmanned task. The power supply required for the vehicle is obtained using batteries. Though pesticide spraying is important to increase the production yield, unregulated usage of Pesticides will damage the soil and the crops.

X. CONCLUSIONS

Proposed system is very efficient and can be used in agricultural field very effectively. This technology is most suitable for Energy Alternate Device for power sprayers. This system is user friendly and also environment friendly as it doesn't produce any pollution. Also, this robot can be used at very remote place where fuel and power are not available. As this sprayer is economical than that of the conventional engine operated sprayers. Moreover, the same technique and technology can also be extended for all types of power sprayers. By using this robotics sprayer, we have to reduce manpower. This sprayer is remote control based so Hazardous chemical is not affected on human. This sprayer increases the speed of work. It is a multi-purpose sprayer. This project work described here is quite useful in the agriculture fields. Thus, the Plant watering the system is successfully designed and tested for the performance, which was found Satisfactory.

REFERENCES

1. A. Linz, A. Ruckelshausen and E. Wunder," autonomous service robots for orchards and vineyards:3d simulation environment of multi sensor board navigation and applications"
2. Stephen Michael Faivre, Noel Wayne Anderson, Mark William Stelfod, <https://www.google.com/patents/W02008136804A1>,
3. F. Pezzi, V. Rondelli (august 2000)," The performance of an air-assisted sprayer operating in vines", Journal of agricultural engineering research, Volume 76, issue 4, pg 331-340.
4. Burrell, J Brooke T and Beckwih, R," Vineyard computing: sensor networks in agricultural Production", pervasive computing, IEEE (volume 3, issue 1)(3rd march 2004), pg 38-45.
5. Isabelle Baldi, Pierre Lebailly," Pesticide contamination of workers in vineyards on France", Journal of exposure science and environmental epidemiology(2006) 16, 115-124. "the problem With pesticides".